

The GLS. Make the best of every ground.



Mercedes-Benz



The new lightness of being.

With time, with success and with experience, ambitions don't diminish. The journey just gets more enjoyable. More effortless. Safer. Everything feels somehow lighter when you travel in the GLS, the SUV in the S-Class. Peace and serenity? You've never experienced them like this before. Power? More than enough. Limits? None that we're aware of.

The new definition of progressiveness.

24 Engine	41 Visionaries never look back. Why would they?
26 An innovation that changes almost everything: DYNAMIC SELECT.	43 The reassuring feeling of driving a Mercedes-Benz.
27 AIRMATIC. The ultimate in continuous smooth operation.	44 Genuine Accessories
29 Exterior – Make a grand entrance.	50 Upholstery, Trim and Alloy
33 Interior. Excitingly luxurious.	51 Paintwork
37 Large as ever. Versatile as never before.	52 Dimensions
38 Infotainment – See it, feel it, touch it, hear it	53 Technical data
	54 Service
	56 Dealer Network

Charisma.
Without any effort at all.



It's an art mastered by very few: the GLS commands its surroundings just by being there – and with an enticingly high-quality design. New features include the powerdomes on the bonnet and the filigree pattern of the radiator grille with its large three-pointed star. This three-dimensional effect is extremely complex to design and produce, but it is what gives the front end of the GLS its signature look.



Effortlessly confident.

Masculine and self-assuredly sporty – on a Mercedes-Benz the size of the GLS, every component is a statement. The powerful rear end with integrated tailpipe trim in a new design, the chrome-look load sill guard and the two-piece full-LED rear light clusters help to define the dynamic character of the GLS. The darker it gets, the more you stand out – for that perfect appearance.



Off the beaten track.
Leaving the familiar behind.

Shift perspective.

Poised, assertive and dynamic. Makes a statement of confidence both on and off the road. Sleek bumper, stylish tail lights, chrome-look details, roof rails, light-alloy wheels and underguard. All these complimented with the sporty looks and a dashing personality. Makes an impression, commands respect.





There are still seats to be had in seventh heaven.

You travel in such luxury in the GLS that you really ought to share it. Three rows of seats as standard offer top-level comfort and ample space for up to seven occupants. The seats can be used very flexibly, featuring as they do backrest angle adjustment for the second row and electric folding for the third.

The off-road adventure. The GLS is ready.

The comfort, the space, the equipment and appointments – no question about it, the GLS is as if made for long, relaxed journeys. That's why there's an S in GLS. It represents the comfort of an S-Class. But there's a G there too – and at Mercedes-Benz that stands above all for: harder, higher, further. Our competence with all things off-road is legendary, a reputation established above all by the indestructible G-Class. There's more than just one letter of that name in the GLS. The off-road transmission mode adjusts the suspension and drive components to the optimum configuration.





All the best locations.

Sometimes air can be a real luxury. When we take a deep breath, when we stand in a rough wind – or when we travel in the GLS. The AIRMATIC air suspension with the ADS PLUS Adaptive Damping System cushions the passengers at a whole new level of comfort. Further features include the 9G-TRONIC 9-speed automatic transmission and numerous driving assistance systems – available for the first time in this class of vehicle. It is hard to think of a more comfortable, more assured and safer way to travel.

Enhance your prospects.



S-Class, when that's what you want.
SUV, when that's what you need.



That's what luxury is about: investing everything in the business and even more in the family. Spending time with friends, yet sometimes just being alone. Luxury is the perfect balance. And that is so important that the GLS has a special Controller for it: the DYNAMIC SELECT Controller. You can use it to select any one of the five transmission modes, ranging from pronounced comfort to off-road capability. Because every day is different. And every journey and every person, as well.

Indoor living.

Digital life can be exciting. In the GLS it involves high-resolution displays, a touch-sensitive touchpad and smartphone integration. Highlights of the interiors of the GLS include the standard DYNAMIC SELECT Controller, the large media display with its high-quality glass finish and the touchpad that comes with the COMAND Online. The new 3-spoke multifunction steering wheel in nappa leather, with an airbag cover also in nappa leather, is a sensory experience in its own right.

Luxury. Seven times over.

How reassuring to know that you can just lean back and relax. Enjoy a perfectly co-ordinated colour scheme, with new shades and combinations now available. Sit back and enjoy the black, ginger beige or espresso brown interiors.

Engine - Effortless Superiority

Diesel Engine

Efficient right from the start and endless power. The V6 diesel engine for the GLS offers the perfect solution to every need. What an auditory experience, what a soft, velvety way to deliver power. It's enough to give even the most experienced automotive enthusiast goose bumps. This engine is just ideal for powering the SUV in the S-Class. This Mercedes that oozes self-assurance with every fibre of its being. It's hard to describe the ease with which even such a large SUV accelerates, how smoothly each command to the accelerator pedal is obeyed. An incredible output of 190 kW (258 hp) and a peak torque of 620 Nm translates into almost inexhaustible reserves of power in virtually any driving situation.

Drive System Technologies

The standard-specification **ECO start/stop function** shuts off the engine temporarily at a red light or in a traffic jam in order to lower fuel consumption further.

Cruise control with SPEEDTRONIC allows relaxed and fuel-efficient driving, especially on long journeys. In addition to the desired cruising speed, an individual maximum speed can be set e. g. to be sure of obeying speed limits.



*Please read the disclaimer.

9G-TRONIC Transmission – faster, smoother, more efficient

Sympathetic support from the world's very first 9-speed automatic transmission.

With nine forward gears, the 9G-TRONIC automatic transmission introduces a whole new dimension of efficiency, comfort and dynamism. Its high efficiency helps to reduce fuel consumption. The wider ratio range allows a reduction in engine speed. Performance remains excellent while ride comfort is enhanced and noise levels are reduced. Smaller gear ratio increments and faster gear changes lead to even greater responsiveness and agility. At the same time, 9G-TRONIC impresses with smooth, barely perceptible gear shifting. As 9G-TRONIC is able to skip individual gears, multiple downshifts are possible for fast and powerful sprints.

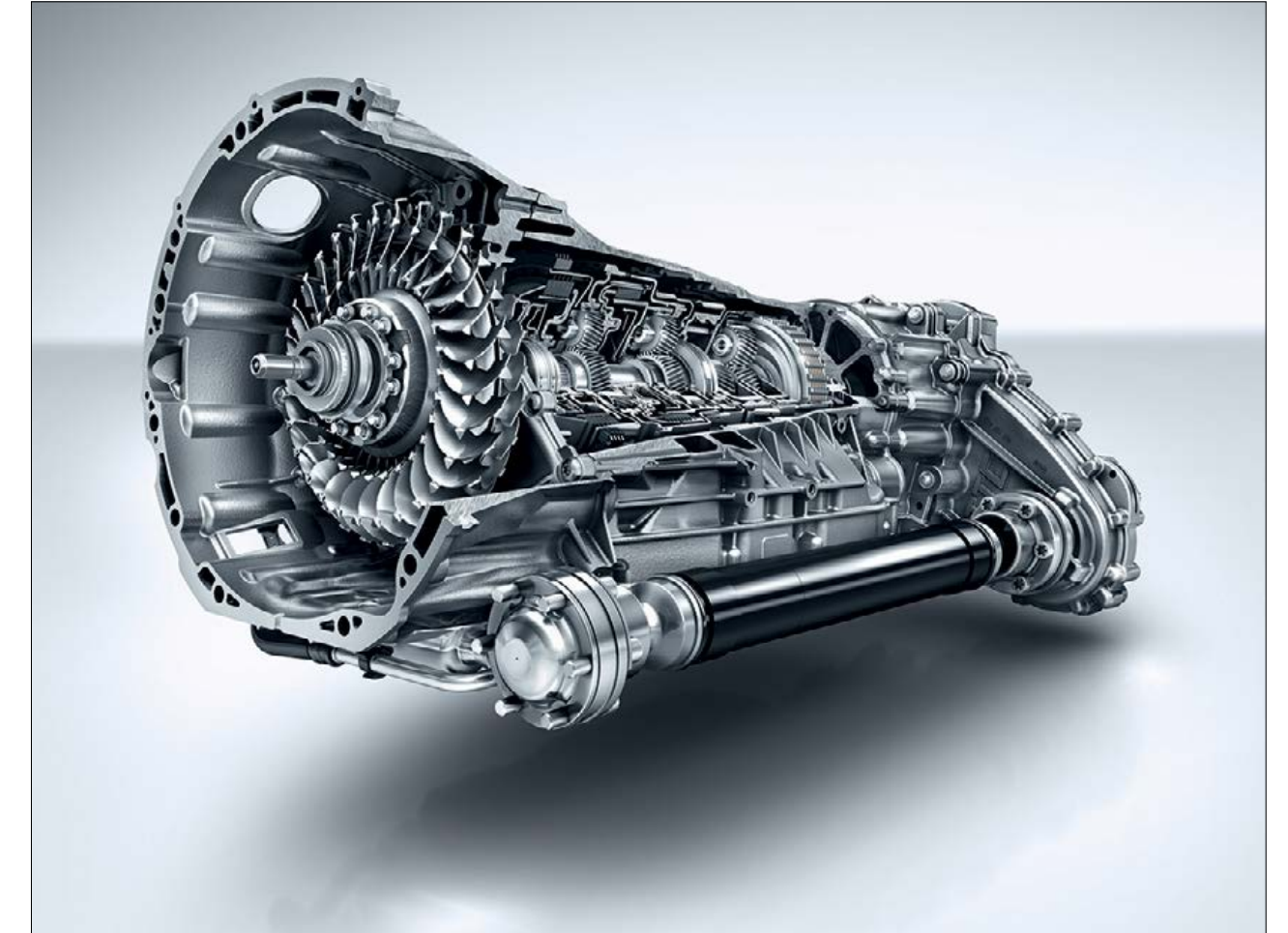

*Please read the disclaimer.

An innovation that changes almost everything: DYNAMIC SELECT.

Comfortable, sporty, winter-optimised or entirely individual suspension settings can be called up with the DYNAMIC SELECT Controller on the centre console. Harmonious and efficient driving is made possible by the “Comfort” transmission mode. “Sport” is characterised by a sportier configuration of the suspension, which has also been lowered by 15 mm, and sportily taut damper settings, in each case in conjunction with the AIRMATIC package, along with more directly responsive steering and modified shift points. The “Slippery” transmission mode provides optimised handling on slippery terrain, while “Individual” allows precise configuration of the various parameters to suit the driver’s wishes.

For those special occasions: the Off-Road Mode

Whether on- or off-road, on easy or difficult terrain, on fast bends or in snow – the Off-Road Mode makes it possible to adjust handling perfectly to the given situation, just by turning the DYNAMIC SELECT rotary switch. The characteristics of the ESP®, 4ETS, ASR, steering, ground clearance, air suspension and damping, for example, are automatically adjusted. The selected transmission mode is displayed in the instrument cluster and in the media display by means of an animation that depicts, for example, gradient and incline angle.



*Please read the disclaimer.

AIRMATIC. The ultimate in continuous smooth operation.

The standard-specification air suspension system **AIRMATIC**, together with the **ADS PLUS adaptive damping system**, ensures a high level of ride comfort and excellent driving dynamics. The damping system adjusts continuously to the actual driving and road conditions at each wheel. Pitching and rolling, for example when cornering or braking, can be effectively reduced. It is possible to select between a comfortable and a sportier configuration for the AIRMATIC package. The level control system ensures a constant vehicle level regardless of its load and driving condition. At high speeds, and in the “Sport” transmission mode, the vehicle is lowered by up to 15 millimetres in order to reduce wind

resistance and further increase stability. Off-road capability can be increased by raising the level by up to 60 mm – depending on the specification.

Improved comfort. Improved dynamism. Improved traction.

Excellent handling on any surface – thanks to **4MATIC permanent all-wheel drive** in combination with ABS, ESP® and the electronic traction system 4ETS. On- or off-road, in wet weather or slippery terrain: traction, driving dynamics and driving stability are improved.



*Please read the disclaimer.



Exterior – Make a grand entrance.

The exterior of the GLS underlines the vehicle’s elegance and value even more emphatically. The modernised design elements convey the Mercedes-Benz’s hallmark “sensual purity” and strengthen the presence and imposing nature of the GLS, especially in the front-end design.

Exterior Highlights

LED Intelligent Light System

Daytime running lamps featuring LED fibre optics integrated into the upper part of the headlamps

Contoured power domes on the bonnet

Upright radiator trim with two sculpted louvres around the centrally placed Mercedes star

Clearly accentuated front bumper – without daytime running lamps, which are now integrated in the main headlamps

Mirror package with brand logo projection from side mirrors

Aluminum-look running boards with rubber studs

50.8 cm (20-inch) 10-spoke light-alloy wheels

Tail lights with all lighting functions in LED or fibreoptic technology including brake lights, reversing lights and rear fog lamp

Rear bumper with new-look lower section

Visible tailpipe trim elements for a sportier look



Exterior – Standard Equipment

LED Intelligent Light System – more visibility in every situation

For the best possible visibility on country roads and motorways, when cornering and on bends, the low beam mode of the LED Intelligent Light System automatically adapts to the weather, lighting and driving conditions. The LED Intelligent Light System thus makes a key contribution to safe driving. LED technology impresses with its very low energy consumption, long operating life and pleasant white light that comes close to the spectrum of natural daylight.



*Please read the disclaimer.

Mirror package – more comfort, improved visibility

The exterior mirrors are electrically folding in order to protect the housing. For enhanced perception, the exterior mirror on the driver's side and the rear-view mirror are automatically and continuously self-dimming. A highlight is the surround lighting with projection of the brand logo.



Aluminium-look, illuminated running boards with rubber studs

A real eye-catching feature are the illuminated, aluminium-finish running boards. They are mounted on the side at the height of the side skirts, thus making it easier to get into the front and rear. Slip-resistant rubber studs ensure a firm foothold.



Visible tailpipe trim elements for a sportier look

The 2-pipe exhaust system with integrated chrome-plated tailpipe trim sets a sporty tone at the rear, so once again clearly emphasising the vehicle's power and performance.



*Please read the disclaimer.



*Please read the disclaimer.

Interior. Excitingly luxurious.

The S in the name comes with a commitment. To an exceptionally high standard of equipment and appointments – right from the start. The modernised interior and meticulous attention to detail enhances the luxurious overall impression given by the interior.

Interior Highlights

3-spoke multifunction steering wheel in nappa leather, with steering-wheel gearshift paddles and 12 function buttons, as well as airbag cover in nappa leather

Sporty look of pointer and dial of instrument cluster

Upper section of dashboard in ARTICO with new design and new arrangement of the central air vents

Panoramic sliding sunroof

Centrally positioned Media Display, glass display with 20.3 cm screen (diagonal size) for COMAND Online

Comfort seats in ARTICO leather with 4-way lumbar support for driver and front passenger

Ambient lighting – with a choice from three colours

Front and rear ashtray inserts in the stowage compartments as well as cigarette lighter in the front

Temperature-controlled cup holder

THERMOTRONIC - automatic climate control system with 3 climate zones and vents till the 3rd seating row



*Please read the disclaimer.

Surrender before such seating comfort.

ARTICO is made from a textile backing material which is coated with polyurethane or PVC. After the paint is applied, an embossing roller gives the man-made leather an embossed finish typical of leather. Man-made leather is even more resistant than genuine leather to the effects of water and sunlight. ARTICO man-made leather can also be combined with upholstery fabrics, with the seat cushions in fabric and the side bolsters in ARTICO man-made leather.



*Please read the disclaimer.

3rd seat row with easy access at the touch of a button. The 3rd row of seats provides space for a further two passengers. Thanks to the EASY-ENTRY this is easily accessible and, depending on how much space is needed, can be electrically folded. The switches for the EASY-ENTRY system are located on the top of the backrests. Pressing these switches causes the head restraints to retract electrically, while the backrests fold down. The bench seat is then folded forward. This system facilitates access to the 3rd seat row from both sides at the touch of a button. The backrests and bench seat of the 2nd row of seats can be folded forward electrically with a split of 60% (left) to 40% (right).



Interiors – Standard Equipment

Memory package

The Memory package is especially convenient if the vehicle is used by more than one person. Up to three different positions for the electrically adjustable front seats, steering column and exterior mirrors can be stored and retrieved at the touch of a button.



Ambient lighting

The Memory package is especially convenient if the vehicle is used by more than one person. Up to three different positions for the electrically adjustable front seats, steering column and exterior mirrors can be stored and retrieved at the touch of a button.



*Please read the disclaimer.

Interiors – Standard Equipment

Temperature-controlled cup holder

A cool or warm drink always within reach – a convenience enjoyed by driver and front passenger thanks to the temperature controlled cup holder. Holds bottles, cans and mugs securely in place in the centre console. A temperature of between 8° and 55° C can be maintained, according to what is required.



*Please read the disclaimer.

THERMOTRONIC automatic climate control

The automatic climate control system with 3 climate zones and 3 climate modes provides an individual feel-good climate on board. The temperature and air distribution can be regulated separately for driver and front/rear passengers. Sensors are used to ensure that the desired climate is kept constant in each zone.



Panoramic sliding sunroof

With its large glazed areas, this roof system ensures a particularly bright and welcoming ambience in the interior. It consists of a fixed panoramic glass sunroof above the 2nd seat row and an electrically operated sliding glass front section for ventilation of the interior as required.



Large as ever. Versatile as never before.

With a capacity of up to 2300 l, the load compartment of the GLS is the largest in this segment. The load space behind the second seat row is 680 l. The standard-fit EASY-PACK tailgate, the 60:40 split folding rear seats and the headroom of 1.95 m below the open tailgate make the load compartment exceptionally versatile and allow easy loading and unloading.

Load compartment and variability

The EASY-PACK tailgate can be opened and closed at the touch of a button for more convenient loading and unloading of the load compartment. The EASY-PACK load

compartment cover protects luggage from the sun and prying eyes. It consists of a retractable cover, which is mounted behind the rear seats and can be removed at any time. Six lashing eyelets on the floor of the load

compartment and the backrests of the third row of seats, together with a folding bag hook on the right-hand side of the load compartment, provide practical help with transporting a diverse range of items.



*Please read the disclaimer.

Infotainment - See it, feel it, touch it, hear it

Navigation, telephone, audio, video, internet – the control and display system **COMAND Online** ensures that the driver has all these and many other functions in clear view and within easy reach. Information is displayed on a smartly finished and centrally positioned glass screen with a diagonal measurement of 20.3 cm. The **touchpad** enables intuitive

operation by means of hand gestures, and users can input letters, special characters and numbers in their own natural handwriting. Three additional buttons control key functions such as the “Back” function, the “Favourites” menu and the audio quick menu. Using the touchpad or buttons gives users clear haptic feedback.



*Please read the disclaimer.



*Please read the disclaimer.

Infotainment

Smartphone Integration package – for safe and intuitive use of a smartphone

With this package, it is possible to integrate the iPhone® into the vehicle via Apple CarPlay™ and operate it by voice control – certain functions can also be operated via the vehicle controls. This makes safe use possible while on the move. In the case of Apple CarPlay™, for example, the system supports telephone operation, navigation and music reproduction, receiving and sending text messages and emails, as well as Siri voice control. The selected apps from third-party providers that are also supported include Stitcher Radio and Spotify. To prevent driver distraction while on the move, there is no complete duplication of smartphone content.



*Please read the disclaimer.

Garmin® Map Pilot

User-friendly navigation, precise map data and excellent route guidance – the Garmin® MAP PILOT brings all the familiar benefits of a Garmin® navigation system. The map with the trademark Garmin® look and feel is shown on the multimedia system's large high-resolution colour display with additional navigation instructions appearing in the instrument cluster. 3D views with exact visualisation of roads and buildings as well as photo-realistic junction and lane assistants make it easy for drivers to orientate themselves. Intuitive operation is possible using the Controller in the centre console.



Visionaries never look back. Why would they?

Assistance systems

Active Parking Assist

Makes finding a parking space as well as parking in both parallel and end-on spaces easier; it also assists when leaving a parallel parking space. The system automatically steers the vehicle into parking spaces, relieving the driver of the work of steering and braking.



360° Camera

The 360° camera included in the Parking package provides you with a realistic all-round view thanks to the interaction of four cameras. The camera is switched on automatically when reverse gear is selected. Alternatively, it can be activated by the driver whenever required. The vehicle and its immediate surroundings can be shown as a bird's-eye view in the multimedia system display. Even obstacles below the window line are visible to the driver.



*Please read the disclaimer.

The reassuring feeling of driving a Mercedes-Benz.

We are the first automotive manufacturer worldwide to have developed an integral safety concept, aimed at avoiding accidents, ensuring ideal responses to dangers and lessening the consequences of accidents. For the occupants of a Mercedes as well as for other road users.

Adaptive Highbeam Assist Plus

The Adaptive Highbeam Assist Plus allows the main-beam headlamps to be kept on permanently since oncoming traffic or vehicles in front are masked out in the beams' cone of light.



Adaptive Highbeam Assist Plus

*Please read the disclaimer.

Crosswind Assist

An additional function of the ESP® is the Crosswind Assist with automatic lane-correcting brake actuations. A permanent all-wheel drive, 4MATIC, ensures stability, dynamism and safety, even in difficult weather or road conditions. Brake force distribution is via a single-stage transfer case.

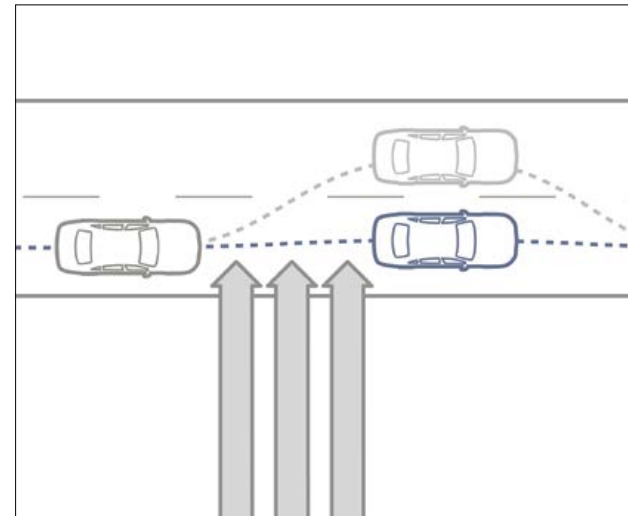

Crosswind Assist

ATTENTION ASSIST

This system can improve driving safety, especially on long journeys and at night. ATTENTION ASSIST monitors the steering behaviour of the driver to recognise typical signs of drowsiness and severe loss of attention, and gives a visual and audible warning of impending microsleep.



In the event of danger

The PRE-SAFE® anticipatory occupant protection system is able to identify critical driving situations in advance and to initiate precautionary measures to protect the vehicle's occupants if an accident appears imminent. Such measures include reversible belt tensioning or automatic closing of open side windows, for example.

In an accident

A total of **eight airbags** protect the occupants in the event of an accident, so potentially reducing the risk of serious injury: adaptive airbags and sidebags for the driver and front passenger, sidebags for rear passengers and windowbags. If no one is sitting in the front passenger seat or a child seat is detected, the front passenger airbag can be automatically deactivated. This protects small children from injuries caused by activation of the front passenger airbag. Detection is assured through a pressure sensor.

After an accident

Every Mercedes-Benz is fully trained in first aid. If the worst comes to the worst, the engine can be stopped automatically, the hazard warning lights and emergency interior lighting can be activated, and the central locking can be unlocked.

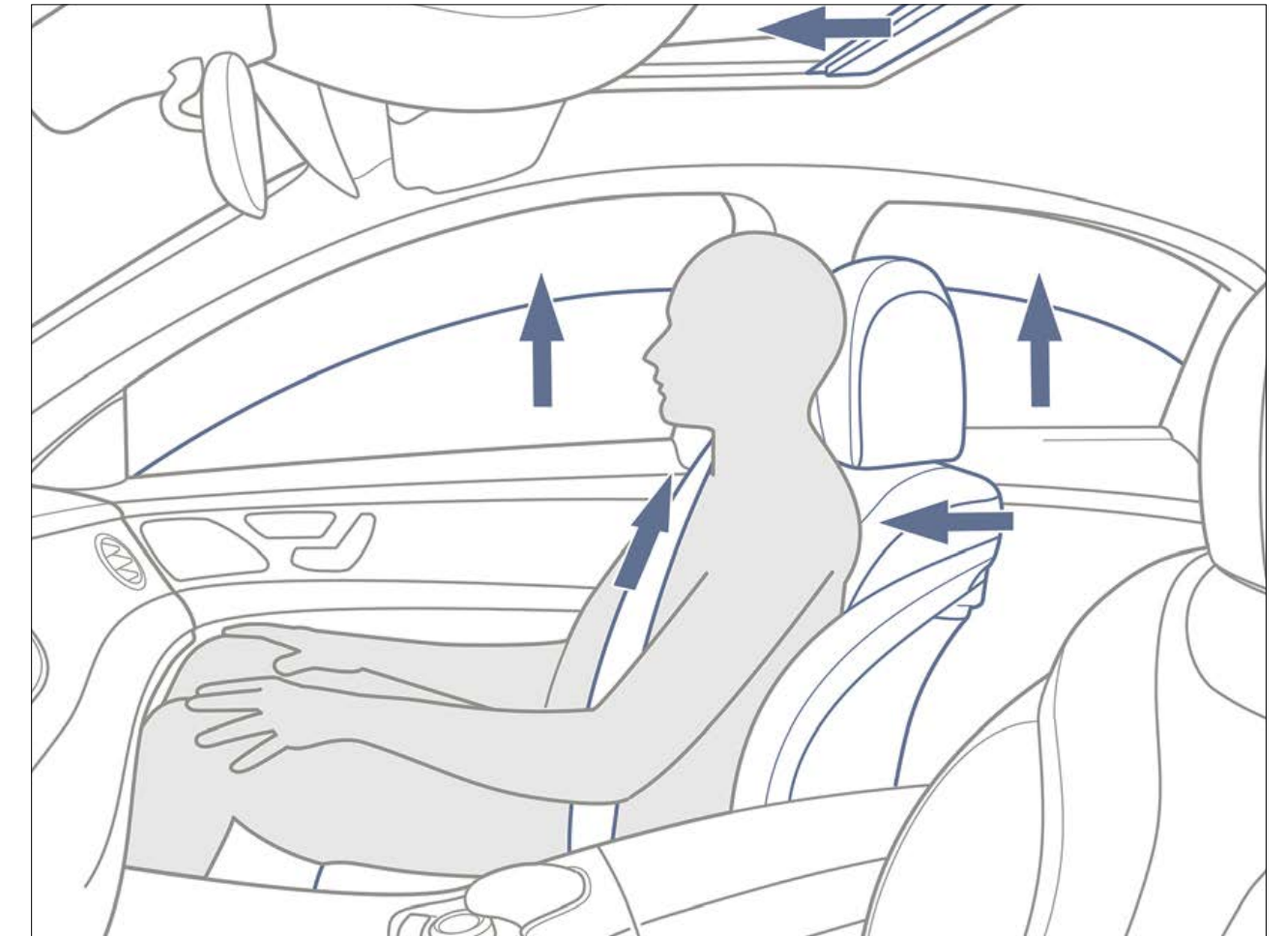

PRE-SAFE®

*Please read the disclaimer.

Genuine Accessories

Use our extensive range of Genuine Accessories to individualise the GLS. These cover almost every conceivable need for even more pleasant, practical and enjoyable motoring.

Use our extensive range of Genuine Accessories to individualise the GLS. These cover almost every conceivable need for even more pleasant, practical and enjoyable motoring.

Genuine Accessories – Highlights at a glance

Ample storage for all those big plans. The aerodynamically designed Mercedes-Benz Roof box XL in metallic black or matt silver, which can be opened from either side, has been especially configured for the GLS and combines innovative technology with safety. Whether you're off on skiing break or a family holiday, its 450 l of load capacity and 75 kg payload are an effective solution to any transport problem.

Transport cycles the easy way, with the New Alustyle roof mounted bicycle rack. Extremely lightweight bicycle rack which weigh only 2.5 kg is designed to be attached to the basic carrier bars. Bicycles can either be attached to the rack once it has been fitted to the roof or before it is fitted.

Make the illuminated Mercedes star shine brightly. The star centred in the radiator grille of your Mercedes will light up courtesy of fibre optic and LED technology when the vehicle is locked and unlocked by remote control, and when a door or the tailgate is opened (only operates if engine is switched off).

The elegantly exclusive appearance is underscored by the 5-twin-spoke light-alloy wheels, painted in himalayas grey with a high-shine finish, with 265/40 R 21 tyres (only for 350 d 4MATIC).



Genuine Accessories

Rear Seat Entertainment System

This elegant DVD system allows the rear passengers to watch DVDs, look at their favorite pictures and even play video games on two superb 17.8 cm color screens and thus keeping them entertained during your journey – and outside the vehicle, as the monitors can be removed from the mount with a click and used anywhere with the aid of the 230V/12V mains adapter additionally provided.

The system's separate DVD players mean that rear-seat passengers have the option of watching a different video source on each of the two tilting monitors, allowing each to select their own individual entertainment. The AV-IN connection and the USB, SD card and AUX interfaces also allow other storage media to be used.

A separately available video cable allows your passengers to watch video and image files from external sources. The system is supplied with two sets of infrared headphones and remote control.



With a range of multimedia connections, 2 sets of infrared headphones and a remote control, the Rear Seat Entertainment System offers everything you need for in-car entertainment.

iPad® Docking Station for Rear Compartment

This ergonomic, crash-proof device introduces the iPad and all of its familiar functions to your Mercedes-Benz. All connections e.g. for your headphones, remain accessible. The mount can be tilted and rotated around 90° in every direction. Available for iPad® 2/iPad® 3/iPad® 4. Supplied with film for iPad® display to protect against scratches and prevent glass splinters in the event of a crash.



*Please read the disclaimer.

Genuine Accessories

Styling

Chrome Door Handle Recess

High-sheen door handle recesses in chrome design. Protect the recess behind the door handle from scratches and offer a high-quality and personalized look.



Chrome Fin Attachments For Bonnet

Fin attachments for bonnet available in a set of 6 pieces. Plastic with electroplated high-sheen chromed finish. Trim for air intakes in bonnet, designed to coordinate with all chrome parts. Robust design with precision fit.



Sports Pedals

For a sporty look – the pedal covers, in brushed stainless steel, add a sporty, high-quality touch to the interior. The genuine parts feature a non-slip rubber stud inlay and comply with Mercedes-Benz's safety.



*Please read the disclaimer.

Genuine Accessories

Alloys

Mercedes-Benz light-alloy wheels not only boost your vehicle's looks, they also offer the ultimate in safety. All wheels are precision-tailored to your vehicle in terms of load profile and dimensions. Before your light-alloy wheels are allowed to accompany you safely on your travels, they are subjected to an extensive development and testing



MB 7-spoke wheel, Himalaya grey 48.3 cm (19 inch), Tyre size: 255/50/R19

programme. Each wheel design has to pass a variety of endurance tests, based on exacting Mercedes-Benz guidelines, all of which exceed statutory requirements. These include special test routines which simulate real challenges on the road and material tests in cutting-edge x-ray facilities. Only once all of the tests have been



MB 5-spoke wheel, Vanadium silver, 48.3 cm (19 inch), Tyre size: 275/55/R19

passed may the wheels be included in the range of genuine Mercedes-Benz light-alloy wheels. Add an individual touch to your vehicle with a tested and approved genuine Mercedes-Benz light-alloy wheel and head for the open road.



MB 10-spoke wheel, Himalaya grey, 50.8 cm (20-inch), Tyre size: 275/50/R20

*Please read the disclaimer.

Genuine Accessories

Cargo and Care

Boot Tub, Shallow

Mobility is the watchword of our times, and there is always plenty to transport on our travels. The shape of the tub, with its slightly raised edge, is optimally tailored to the load area. Very robust - made from impact-resistant, non-split polypropylene, the boot tub is ideal for foodstuffs and liquids. Structured surface prevents the load from sliding around and makes it easier to secure the optionally available stowage crate in place with a protected base.



Boot Tub, Deep

Now take everything you want with the easy-clean boot tub. The deep edge (approx. 25 cm at the sides, 8 cm at the load edge) offers all-round protection. The overall shape is optimally tailored to the load area, ensuring that transporting liquids is not a problem. Even foodstuffs can be transported - the material is food-grade and is easy to clean. The boot tub is light in weight, making it even easier to insert and remove.



Concertina Load Sill Protector

Protects the rear of the car from scratches when you're loading the vehicle - and prevents dirt from the car from getting onto your clothes. Practical design - can be connected to shallow boot tub or reversible mat.



Stowage Crate

A secure hold for items which are prone to tip over or slide around, e.g. shopping bags. Adjustable partitioning elements allow crate to be divided into maximum of four sections. Optimum functionality only in conjunction with shallow boot tub.



Shopping Crate

A collapsible crate that is available in anthracite color. When not in use it can be folded and stowed away in the boot compartment. Features Mercedes-Benz logo and lettering.



Genuine Accessories

Cargo and Care

Mud Flaps

The mud flaps protect the sides, rear and underbody of the vehicle from scratches and damage from loose chippings. They also help protect the following traffic from loose chippings, splash water and dirt. The Mud-Flaps are Precision-tailored to the contours of the vehicle hence do not affect the vehicle's sporty looks. Mud Flaps are made of material that is extremely hard-wearing, durable, UV-resistant. The Mud Flaps can be painted in the colour of your choice.



Floor Mats Tray Type

The Tray Type Mats are made of robust, washable synthetic material that are designed for heavy use. The Mats are designed to cover the entire footwell. The raised edges and structured surface help keep the floor clean and dry. The Mats come with a distinctive Mercedes-Benz lettering.



Coolbox

The cool box not only cools but warms too. It can cool up to 20°C below ambient temperature to a minimum temperature of -2°C at the same time it can be switched to warming function also. The Robust, highly insulated hard case with fabric cover comes with outside pockets and padded shoulder strap. The capacity of Coolbox is 24 litres and can be connected to a 12 V socket in vehicle or to a 230 V power source via separately available rectifier.



Rectifier

Allows the coolbox to be connected to a 230 V socket at home.



Style & Travel Equipment

The head restraint elements are simple to fit and remove. The modular system centres around a base support which can be combined with various products - a coat hanger, a universal hook or a folding table.



*Please read the disclaimer.

*Please read the disclaimer.

Upholstery, Trim and Alloy

UPHOLSTERY
Black
Espresso Brown
Ginger Beige/Espresso Brown

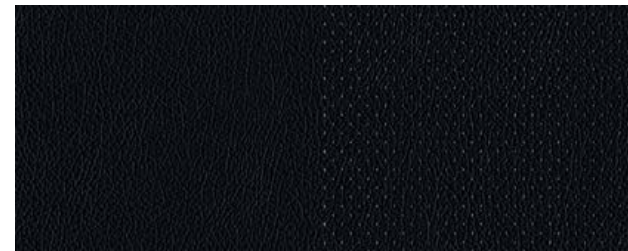

TRIM
Aluminium with light longitudinal grain
Brown open-pore ashwood



ALLOY
10-spoke alloy wheels with 275/50 R 20 tyres



*Please read the disclaimer.

Paintwork

METALLIC PAINTS	DESIGNO PAINTS
Obsidian Black	Citrine Brown
Tenorite Grey	Cavansite Blue
Iridium Silver	

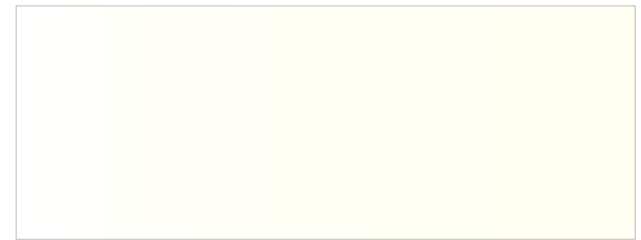

*Please read the disclaimer.

Dimensions

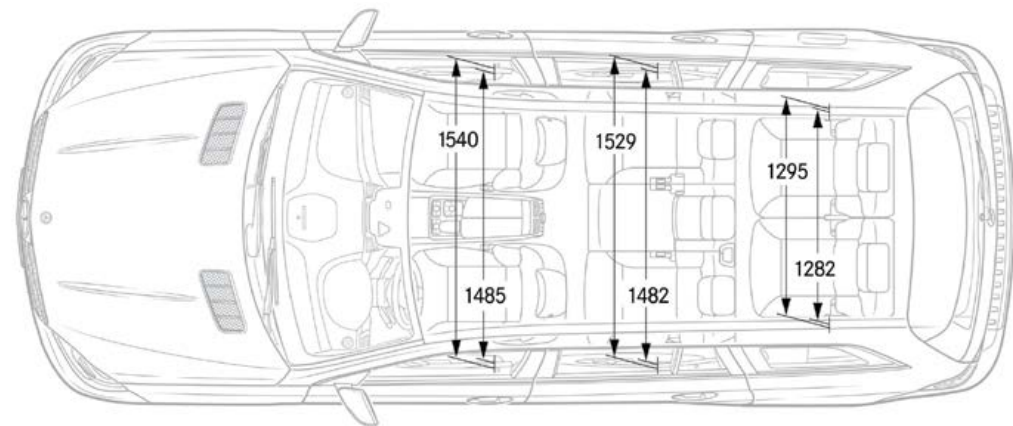
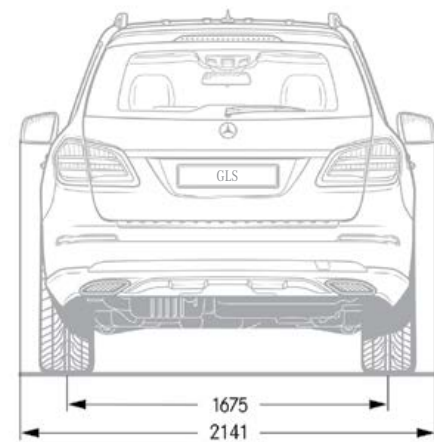
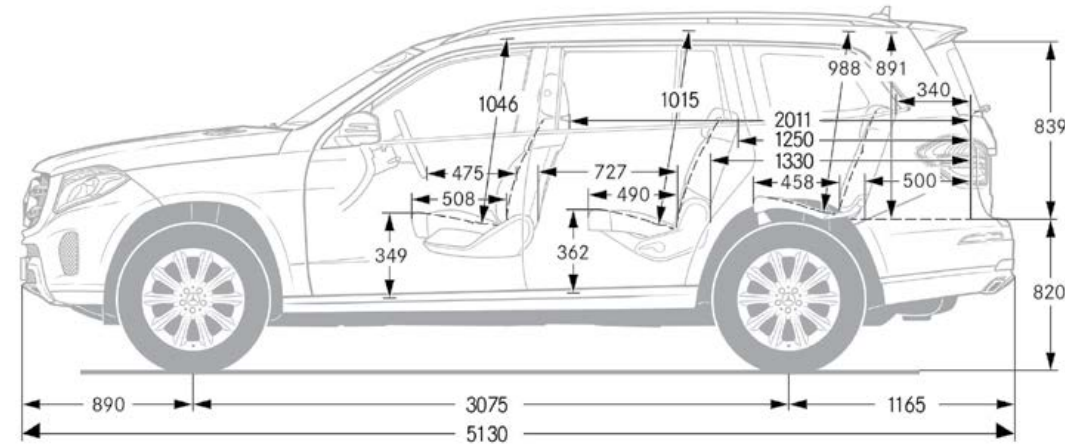
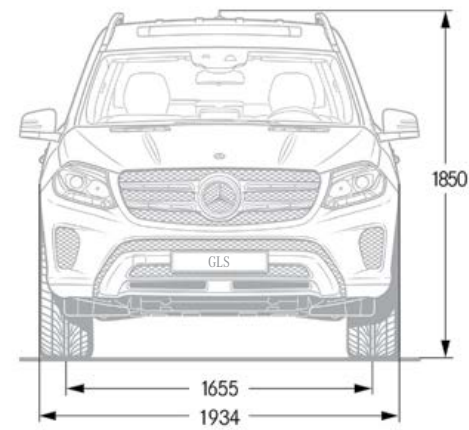

All dimensions in millimetres. The dimensions shown are mean values and apply to standard-specification, unladen vehicles.

*Please read the disclaimer.

Technical data

	GLS 350 d 4MATIC
No. of cylinders/arrangement	6/V
Total displacement in cc	2987
Rated output in kW (hp) at rpm	190 (258)/3400
Rated torque in Nm at rpm	620/1600-2400
Transmission	9G-TRONIC
Acceleration from 0 to 100 km/h in s	7.8
Top speed, approx. in km/h	222
Fuel	Diesel
Tank capacity, of which reserve, approx. in l	100/12.0
Load compartment in l	680-2300
Turning circle diameter in m	12.40
Kerb weight in kg	2455
Perm. GVW in kg	3250
Length /width incl. mirrors in mm	5130/2141
Wheelbase in mm	3075

*Please read the disclaimer.

Service.

The luxurious experience of driving a Mercedes-Benz is converted into a fulfilling ownership experience with a range of exclusive services and special programmes.

Cost of Ownership

There has been a paradigm shift in the buying preferences of Indian consumers over the years, even for the luxury products. The purchase decision not only dwells around cost of acquisition but also the total 'Cost of Ownership' (COO). Amongst the key components of COO in cars are the routine service jobs and the unplanned repair expenses post the warranty period. We are now offering highly-affordable Service Packages and Extended Warranty Programmes which are the most competitive packages in its class. All in all, we provide you with a controlled Cost of Ownership while you benefit from the legendary Mercedes-Benz service quality.

Experience complete peace of mind when you drive the Star

STAR CARE programme offers peace of mind drive for you during warranty period and beyond. While our cars are covered for warrantable repairs up to 3 years without any mileage limitations, as standard, you can also buy STAR CARE Plus programme, offering 4th year extended warranty. Additionally, the programme enhances the resale value of your car.

STAR EASE Service Package gives you the freedom to relax behind the wheel and puts your mind at ease with its range of unique benefits such as defined cost of maintenance and priority handling. STAR EASE Comprehensive package covers essential jobs related to periodic service (viz. oil, filters, consumables, etc.) along with coverage for brake pads, brake discs, wiper blades and wheel alignment & balancing, for a contracted period. For further details on products and pricing, please contact your nearest Mercedes-Benz dealer.

On-Road Assistance Programme As part of our ongoing commitment to you, Mercedes-Benz On-Road Assistance is designed to enhance your overall Mercedes-Benz ownership experience by providing you with 24-hour On-Road Assistance. Mercedes-Benz is the only Luxury car manufacturer to offer round-the-clock On-Road Assistance for 3 years from purchase of vehicle as a standard offering. Peace of mind motoring – guaranteed.



Extended Warranty that guarantees complete peace of mind



The maintenance of your Star is just as peaceful as driving it



Always at your service

Conditions apply.

India's Largest Luxury Car Network

It takes a keen sense of responsibility to provide the Best. Our large network is spread across the country in 40 cities with 83 outlets and is still growing. With world-class showrooms, state-of-the-art workshops and highly skilled personnel, experience the best wherever you go.



DEALER CONTACT:

NORTH & EAST:

BHUBANESWAR:
Tristar Motors: 0-7852944100

CHANDIGARH:
Joshi Autozone: 0172-5050500
Panjab Motors: 0172-4290000

DEHRADUN:
Berkeley Motors: 0135-3054000

DELHI:
T & T Motors, Mohan Co-operative,
Mathura Road: 011-66574300/330
Rajouri Garden: 011-66574400/430

GHAZIABAD:
Silver Arrows: 0-9718200500

GURGAON:
T & T Motors: 0124-4263060/62

JAIPUR:
T & T Motors: 0141-4300000/05

JAMSHEDPUR:
Tristar Motors: 0-7763815720/
0657-6601601/02

JALANDHAR:
Joshi Autozone: 0181-5004444

KANPUR:
Smart Hoops: 0-8795663300

KARNAL:
Berkeley Motors: 0184-3300000

KOLKATA:
Benchmark Interkrafts: 1800 3000 3310

LUCKNOW:
Smart Hoops: 0522-6004008/9

LUDHIANA:
Joshi Autozone: 0161-5055000

MOHALI:
Panjab Motors: 0172-4290000

NOIDA:
Silver Arrows: 0-9999200500

WEST:

AHMEDABAD:
Benchmark Cars: 0-9377662000

AURANGABAD:
B. U. Bhandari: 0-8605121333/
0240-6452601/02

BHOPAL:
Benchmark Cars: 0-9098233233

GOA:
Counto Motors: 0832-2415122

INDORE:
Benchmark Cars: 1800-3000-8844

KOLHAPUR:
B. U. Bhandari: 0231-2661422/
0-8380093555

MUMBAI:
Auto Hangar, Prabhadevi: 022-67434362/63
Auto Hangar, Andheri: 022-67106660/61

Metro Motors, Auto Hangar division
Hughes Road: 022-66123500/11

Shaman Wheels, Off BKC: 022-24228787

NAVI MUMBAI:
Shaman Wheels: 022-24228787

NAGPUR:
Auto Hangar: 0-9223540191/
07104-238180/1/2/3

NASHIK:
Indisch Motoren: 0253-6645555

PUNE:
B. U. Bhandari, Baner: 020-67212129
B. U. Bhandari, Bund Garden: 020-67212131
Trinity Motors: 020-67342525

RAJKOT:
Benchmark Cars: 0-9377750050

RAIPUR:
Auto Hangar: 0771-6537801/0-8518887155

SURAT:
Benchmark Cars: 0-9377660066

VADODARA:
Benchmark Cars: 0-9377390001

SOUTH:

BENGALURU:
Sundaram Motors: 080-22070720/21

Akshaya Motors, Mysore Road:
080-22966300, 0-9066030989

Akshaya Motors, Koramangala:
080-22966296, 0-9019326026

CALICUT:
Bridgeway Motors: 0495-30 55555

CHENNAI:
Trans Car: 044-40200300

Titanium Motors: 044-66498080/8181/8282

COIMBATORE:
Sundaram Motors: 0422-2452020

COCHIN:
Rajasree Motors:
0484-2706332/2706432/2706134
2607027/37/47

HYDERABAD:
Mahavir Motors: 040-43403004

MADURAI:
Sundaram Motors: 0452-2320433/
0-9500966946

MANGALORE:
Sundaram Motors: 0824-2214833/2215833/
0-9008442155

TRIVANDRUM:
Rajasree Motors: 0471-2380377/
0-9846547551

VIJAYAWADA:
Mahavir Motors: 0866-2082559/
0-9885303004

MERCEDES-BENZ CERTIFIED:

AHMEDABAD:
Benchmark Cars: 0-9016665000

BENGALURU:
Akshaya Motors: 0-9019944044

Sundaram Motors: 080-22070746/
0-9880662051

CHANDIGARH:
Joshi Autozone: 0-9878941930/
0172-5050500/510

CHENNAI:
Transcar: 0-9841049994

COIMBATORE:
Sundaram Motors: 0422-2452020

DELHI:
T&T Motors, Mathura Road: 0-9711774424
T&T Motors, West Delhi: 0-9711112243

GHAZIABAD:
Silver Arrows: 0-9718200500

HYDERABAD:
Adishwar: 0-7799633004

INDORE:
Benchmark Cars: 0731-6675520

KOCHI:
Rajasree Motors: 0-9846547311

LUCKNOW:
Smart Hoops: 0522-6004009

MOHALI:
Panjab Motors: 0172-4290000

MUMBAI:
Autohangar India: 0-9223546204,
0-9223547099

Shaman Wheels: 0-9619023450/
022-69543333

PUNE:
B U Bhandari: 020-67212172/0-8605118555

AMG PERFORMANCE CENTERS:

BENGALURU:
Sundaram Motors: 080-22070720/21

DELHI:
T&T Motors: 011-66574309

HYDERABAD:
Mahavir Motors: 0-9885033004/
0-9885653004

MUMBAI:
Auto Hangar: 022-67434360/61/65

PUNE:
B.U. Bhandari: 020-67212131/0-8554055555

Our national toll-free no.:

1800 102 9222

One Call. All Answers.

For a complete list of
Mercedes-Benz outlets,
please explore the dealer locator
tab on www.mercedes-benz.co.in

Mercedes-Benz India Private Limited: E-3, MIDC Chakan - Phase III, Chakan Industrial Area, Kuruli & Nighoje, Tal: Khed, Pune - 410 501 (India)
Toll free No.: 1800 102 9222. e-mail: customerconnect@daimler.com, **website: www.mercedes-benz.co.in**

Please note: This brochure is intended for general information, description and illustration of the Product including optional functions and equipment and may not be specific to a Product since specification of a product may change from time to time. Optional features, functions and equipment etc. may not be present in the Standard or Variant Product or Special Edition Product. Further, Standard specifications of a product may also vary from time to time. Colours may differ from those shown in pictures in the brochure, owing to printing. Mercedes-Benz India reserves the right to make changes, at any point of time, without prior notice, in design, colours, materials, components, equipment, specifications, features, functions, make and models etc. The information given in this brochure shall be regarded as accurate at the time of going to print and may vary thereafter due to any developments or any other reason. Interested parties should confirm with the Authorised Dealer about the correct specification of the product they desire to purchase. For the latest authentic information and updates, kindly contact your nearest Authorised Dealer.

All title, ownership rights and intellectual property rights in and relating to this brochure / magazine or publication material or any copies thereof including but not limited to copyright, logos, names, trademarks, service marks, design, text, images, links, concepts and themes are owned by Daimler AG and/or its subsidiaries collectively or used under authorised license by the Daimler AG. Any reproduction, transmission, publication, performance, broadcast, alteration, license, creation of derivative works or other use in whole or in part in any manner without the prior written consent of the Daimler AG is strictly prohibited.

Month of going to press: May, 2016. Mercedes-Benz cars: The GLS meets Bharat Stage IV equivalent emission norms.

CIN - U34102PN1994PTC083160